

Disc handwheels

Aluminium, blank, rim polished

SPECIFICATION

Types

- Type **A**: without handle
- Type **R**: with revolving handle

Bore codes

- Version **B**: without keyway
- Version **K**: with keyway

Aluminium

- Hub machined
- Rim turned

Rim concentric and square to bore < 0.4

Wheel body

- Rim high-polished
- unmachined body matt shot-blasted

Cylindrical Revolving handles GN 798 (see page 577)

- Plastic, technopolymer, black matt
- Spindle steel, zinc plated, blue passivated

INFORMATION

- Disc handwheels GN 321 have recessed grips at their back.
- Countersunk washers GN 184 (for axial fixing) (see page 971)

TECHNICAL INFORMATION

- Keyway P9 DIN 6885 (see page A16)
- Cross holes GN 110 (see page A17)
- ISO-Fundamental Tolerances (see page A21)

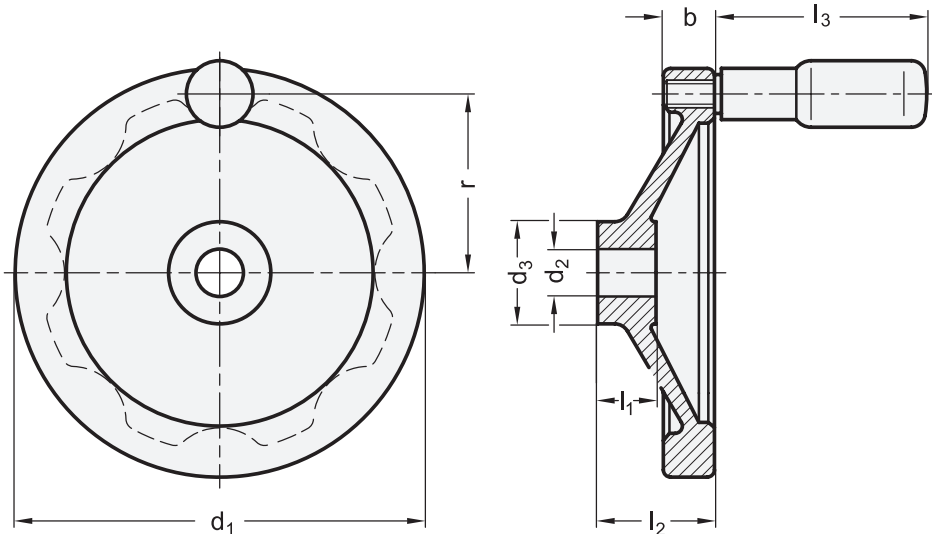



* Complete with Bore codes of the Handwheel (B or K)

B **K**
without keyway with keyway

GN 321-A

Description	d1	d2 H7	d3	b	l1	l2 ≈	⚖
GN 321-80-*10-A	80	10	28	13	16	26	134
GN 321-80-*12-A	80	12	28	13	16	26	127
GN 321-100-*10-A	100	10	28	14	17	30	200
GN 321-100-*12-A	100	12	28	14	17	30	190
GN 321-125-*12-A	125	12	31	15	18	33	318
GN 321-125-*14-A	125	14	31	15	18	33	290
GN 321-140-*14-A	140	14	36	16.5	19	36	431
GN 321-140-*16-A	140	16	36	16.5	19	36	427
GN 321-160-*14-A	160	14	36	18	20	39	460
GN 321-160-*16-A	160	16	36	18	20	39	450
GN 321-200-*18-A	200	18	45	20.5	24	45	885
GN 321-200-*20-A	200	20	45	20.5	24	45	875
GN 321-250-*22-A	250	22	48	23	28	51	1522
GN 321-250-*26-A	250	26	48	23	28	51	1479

GN 321-R

Description	d1	d2 H7	d3	b	l1	l2 ≈	l3 ≈	r	Ø Handle	⚖
GN 321-80-*10-R	80	10	28	13	16	26	44	33.5	16	153
GN 321-80-*12-R	80	12	28	13	16	26	44	33.5	16	149
GN 321-100-*10-R	100	10	28	14	17	30	58.5	42.5	18	215
GN 321-100-*12-R	100	12	28	14	17	30	58.5	42.5	18	213
GN 321-125-*12-R	125	12	31	15	18	33	61.5	54	22	403
GN 321-125-*14-R	125	14	31	15	18	33	61.5	54	22	383
GN 321-140-*14-R	140	14	36	16.5	19	36	76.5	61	24	431
GN 321-140-*16-R	140	16	36	16.5	19	36	76.5	61	24	427
GN 321-160-*14-R	160	14	36	18	20	39	76.5	71	24	665
GN 321-160-*16-R	160	16	36	18	20	39	76.5	71	24	655
GN 321-200-*18-R	200	18	45	20.5	24	45	86.5	89	25	940
GN 321-200-*20-R	200	20	45	20.5	24	45	86.5	89	25	930
GN 321-250-*22-R	250	22	48	23	28	51	86.5	113	25	1520
GN 321-250-*26-R	250	26	48	23	28	51	86.5	113	25	1480

Weight bore code B